

ALDEANA

MANANTIALES

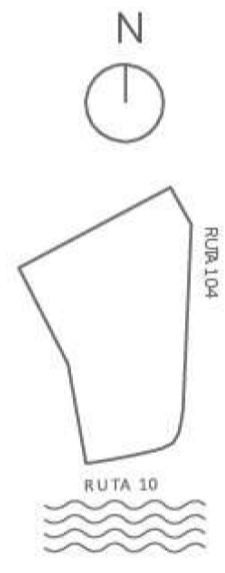

WWW.ALDEANAMANANTIALES.COM
info@aldeanamanantiales.com



RUTA 104

RUTA 10

PROYECTO
MRA+A
ARQUITECTOS

DESARROLLO
ALPES
PROPERTY MANAGEMENT

ASESORA
URBANIA
DESARROLLOS

DIRECCIÓN DE OBRA
LE
ARQUITECTURA

Todos los planos y elementos que se describen corresponden al anteproyecto y están sujetos a posibles modificaciones. Las dimensiones indicadas son aproximadas. Se podrá realizar sin notificación previa, variantes de orden estético o utilitario, tanto en bienes comunes como propios, siempre dentro de los admitidos por la reglamentación municipal vigente. El contenido de este folleto no constituye parte de un documento legal relacionado con las propiedades que se exponen y no representa ningún compromiso entre las partes. Las imágenes utilizadas son solo de referencia. Las medidas finales surgirán del plano de subdivisión definitivo.

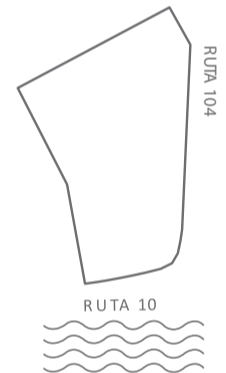
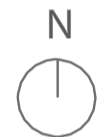
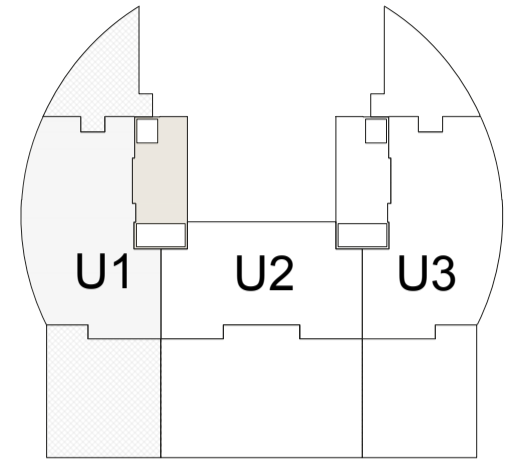
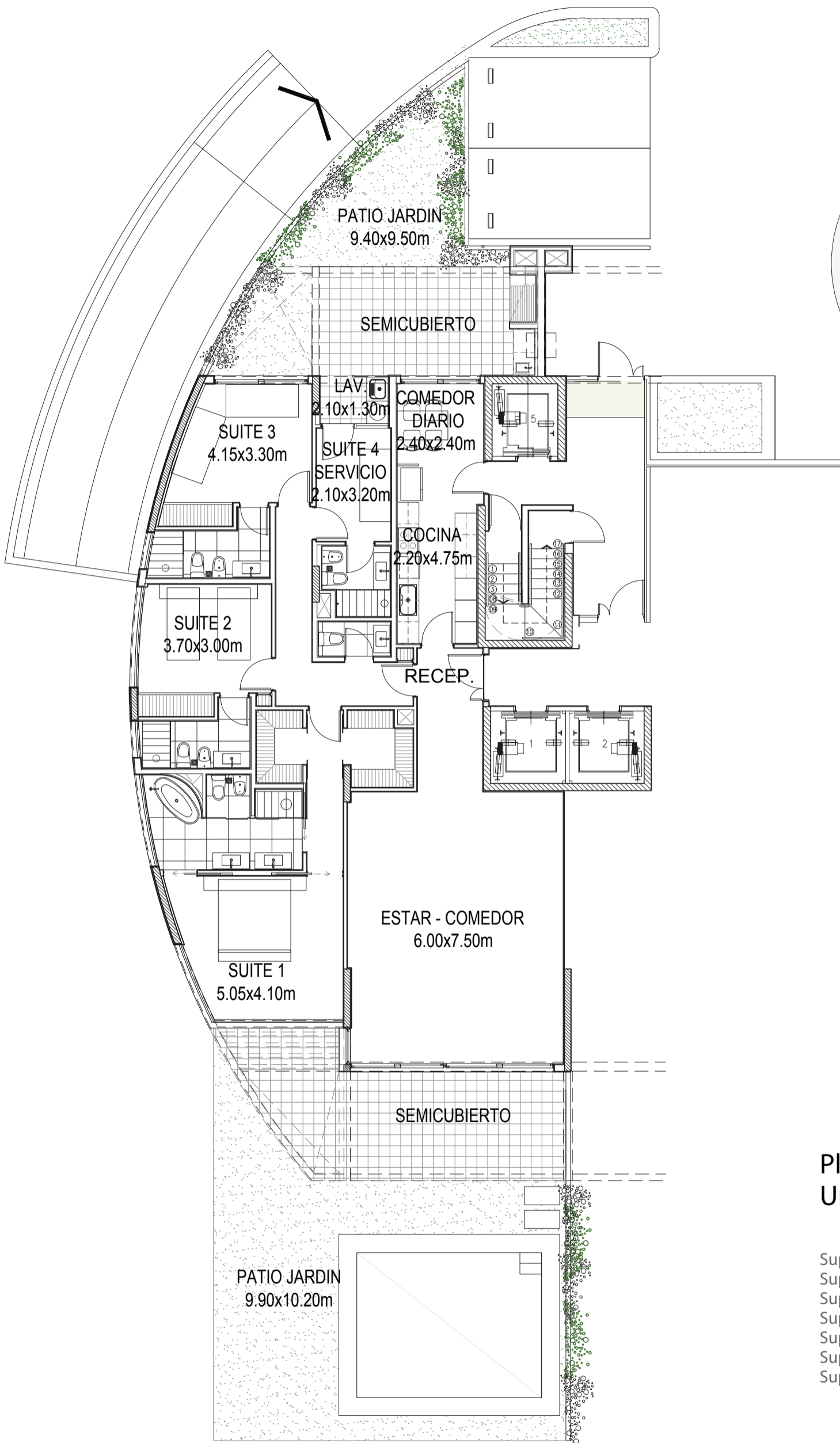

Planta Baja Unidad 1

Sup. Cubierta:	183.71 m ²
Sup. Semicubierta:	40.03 m ²
Sup. Exterior:	112.57 m ²
Sup. Común:	8.58 m ²
Sup. Amenities:	12.85 m ²
Sup. Cochera + Baulera:	15.00 m ²
Sup. Total:	372.74 m²

PROYECTO

MRA+A
ARQUITECTOS

DESARROLLO

ALPES
PROPERTY MANAGEMENT

ASESORA

URBANIA
DESARROLLOS

DIRECCIÓN DE OBRA

LE
ARQUITECTURA

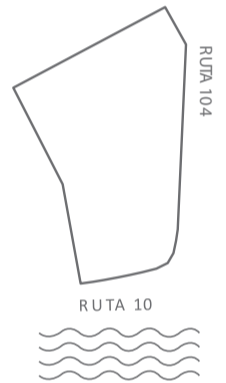
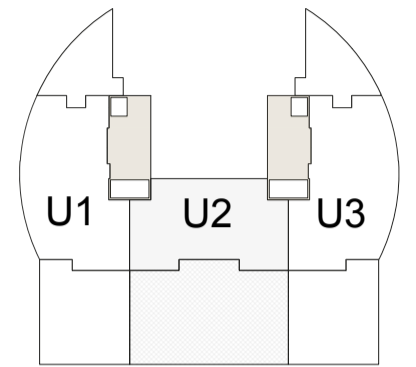
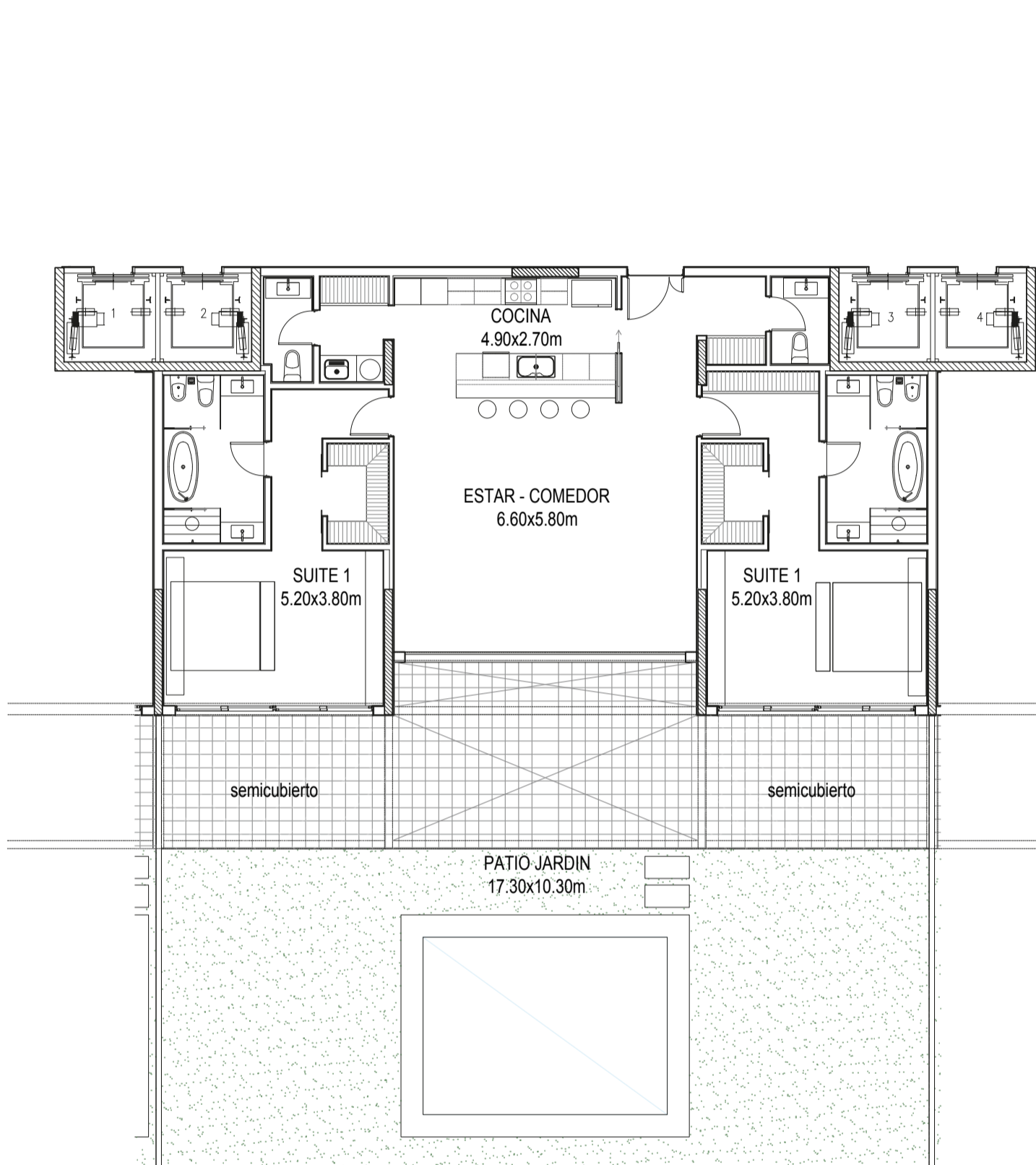

Planta Baja Unidad 2

Sup. Cubierta:	157.41 m ²
Sup. Semicubierta:	31.45 m ²
Sup. Exterior:	153.77 m ²
Sup. Común:	8.58 m ²
Sup. Amenities:	11.01 m ²
Sup. Cochera + Baulera:	15.00 m ²
Sup. Total:	377.22 m ²

PROYECTO

MRA+A
ARQUITECTOS

DESARROLLO

ALPES
PROPERTY MANAGEMENT

ASESORA

URBANIA
DESARROLLOS

DIRECCIÓN DE OBRA

LE
ARQUITECTURA

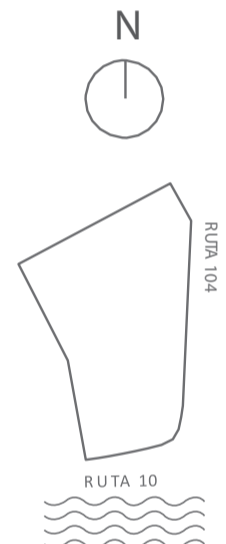
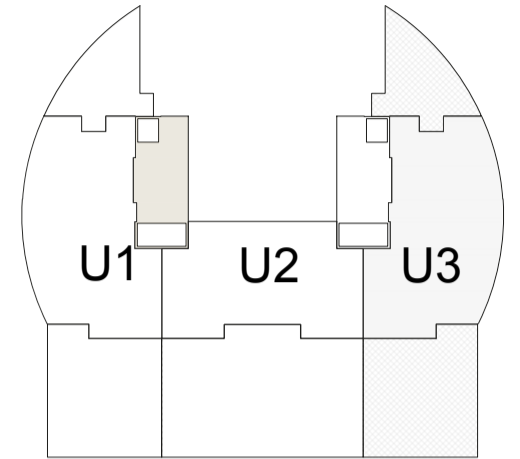
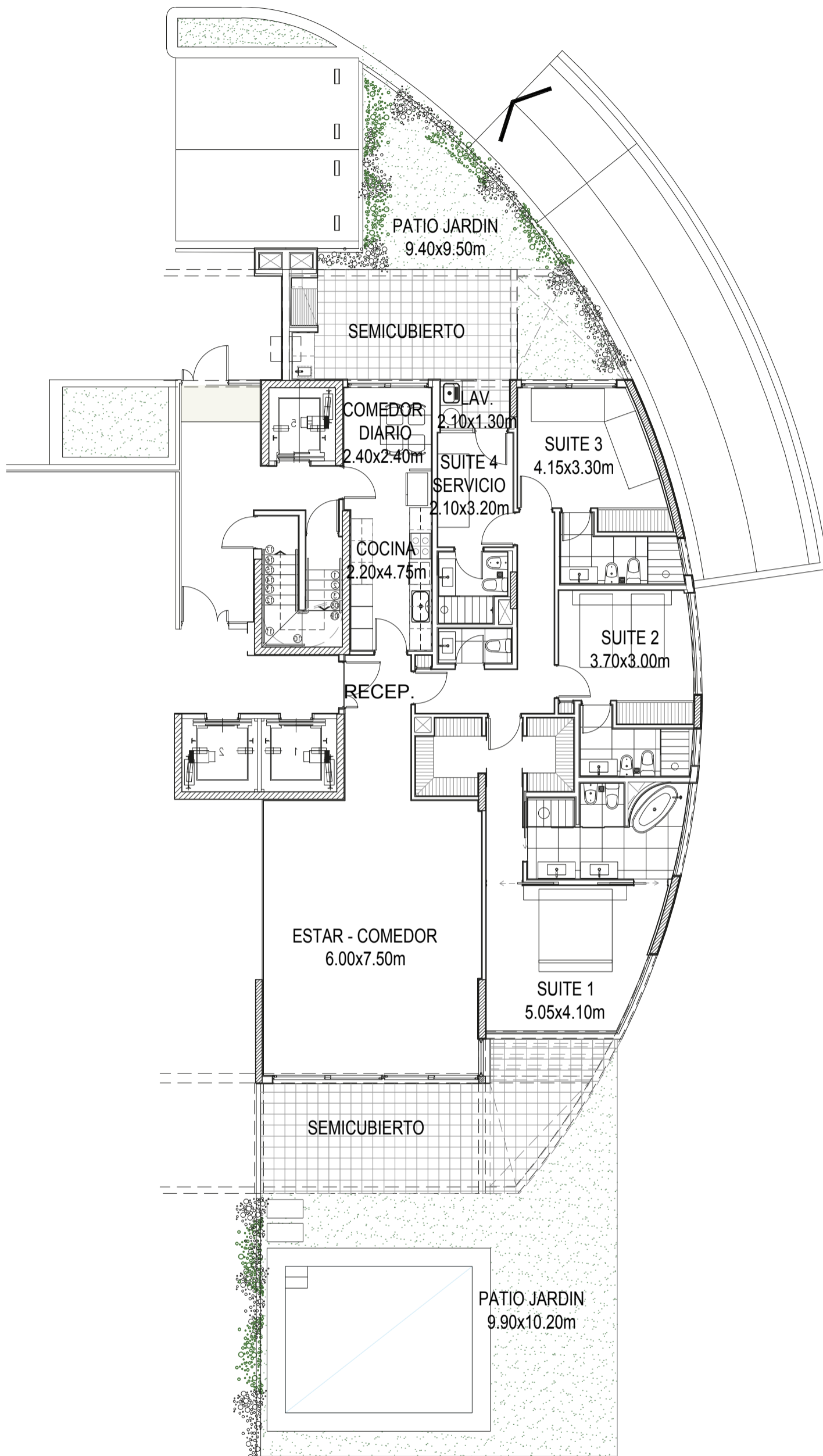

Planta Baja Unidad 3

Sup. Cubierta:	183.71 m ²
Sup. Semicubierta:	40.03 m ²
Sup. Exterior:	112.57 m ²
Sup. Común:	8.58 m ²
Sup. Amenities:	12.85 m ²
Sup. Cochera + Baulera:	15.00 m ²
Sup. Total:	372.74 m ²

PROYECTO

MRA+A
ARQUITECTOS

DESARROLLO

ALPES
PROPERTY MANAGEMENT

ASESORA

URBANIA
DESARROLLOS

DIRECCIÓN DE OBRA

LE
ARQUITECTURA

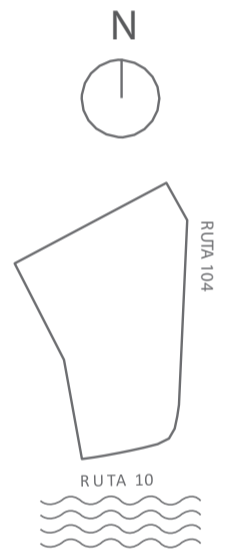
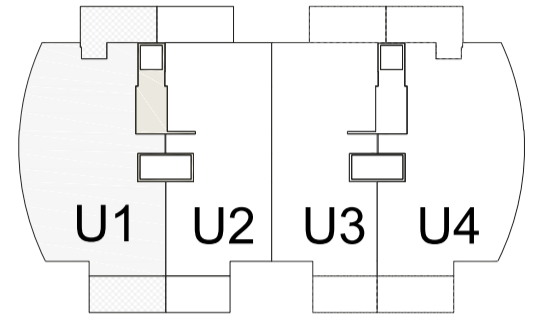
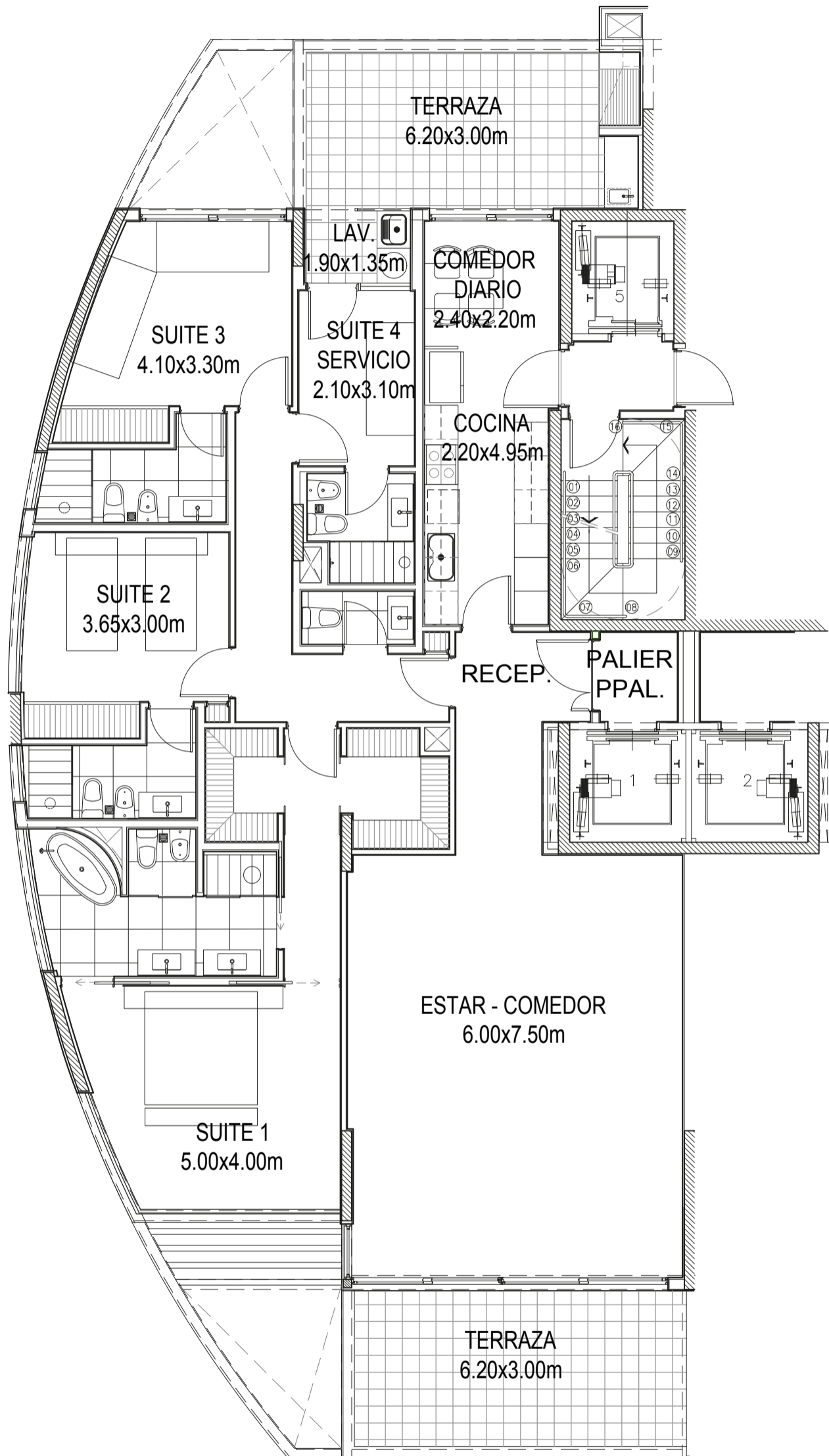

Planta tipo Unidad 1

Sup. Cubierta:	187.05 m ²
Sup. Semicubierta:	40.42 m ²
Sup. Común:	8.58 m ²
Sup. Amenities:	13.10 m ²
Sup. Cochera + Baulera:	15.00 m ²
Sup. Total:	264.15 m ²

PROYECTO

MRA+A
ARQUITECTOS

DESARROLLO

ALPES
PROPERTY MANAGEMENT

ASESORA

URBANIA
DESARROLLOS

DIRECCIÓN DE OBRA

LE
ARQUITECTURA

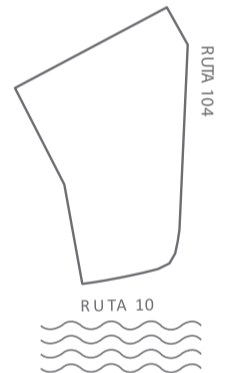
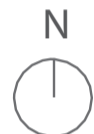
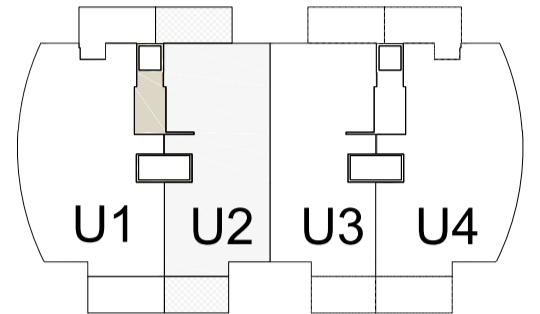
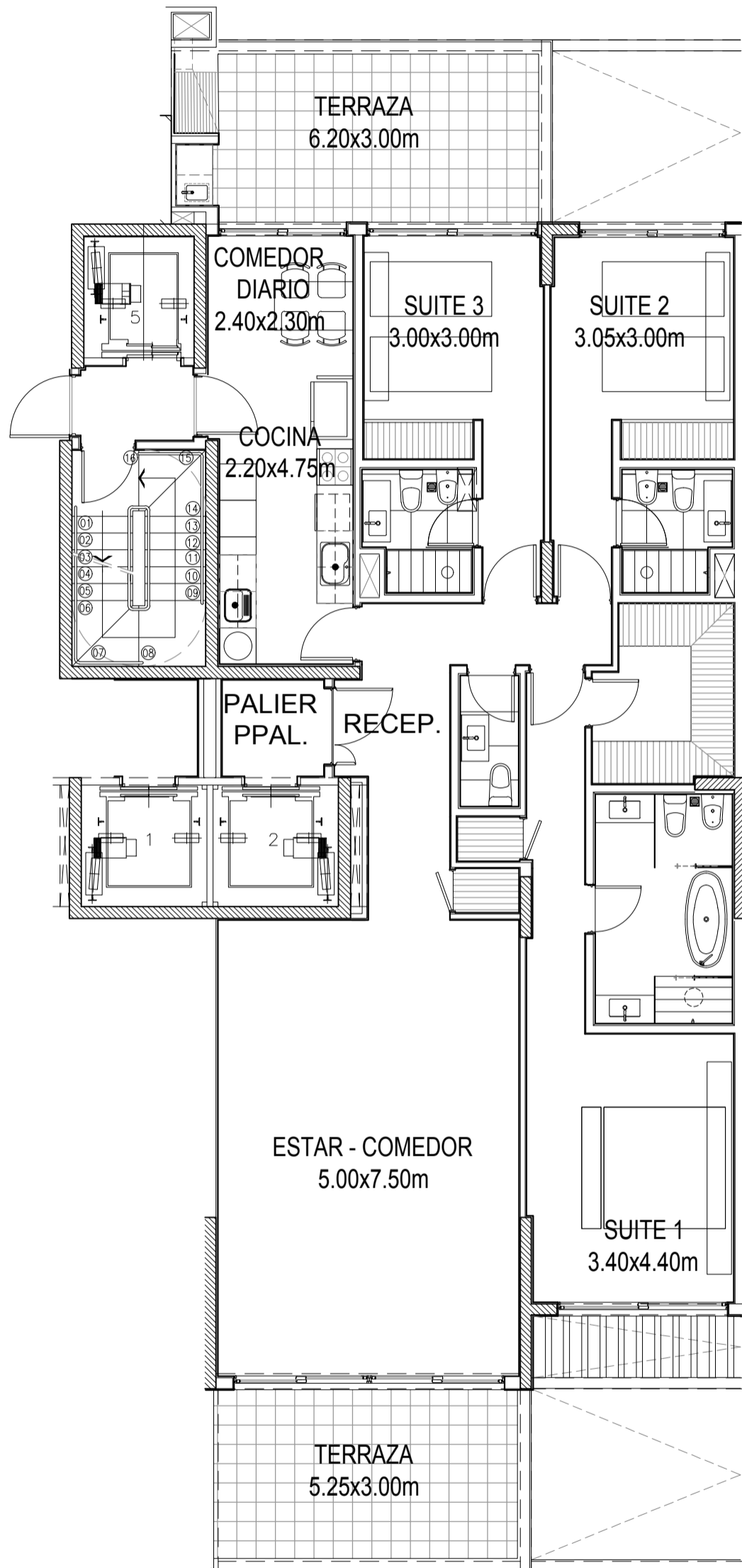

Planta tipo Unidad 2

Sup. Cubierta:	157.45 m ²
Sup. Semicubierta:	34.78 m ²
Sup. Común:	8.58 m ²
Sup. Amenities:	11.02 m ²
Sup. Cochera + Baulera:	15.00 m ²
Sup. Total:	226.83 m ²

PROYECTO

MRA+A
ARQUITECTOS

DESARROLLO

ALPES
PROPERTY MANAGEMENT

ASESORA

URBANIA
DESARROLLOS

DIRECCIÓN DE OBRA

LE
ARQUITECTURA

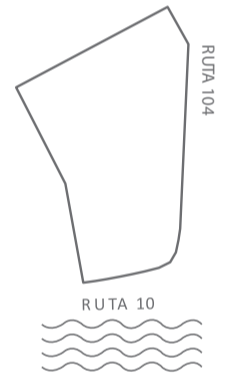
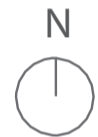
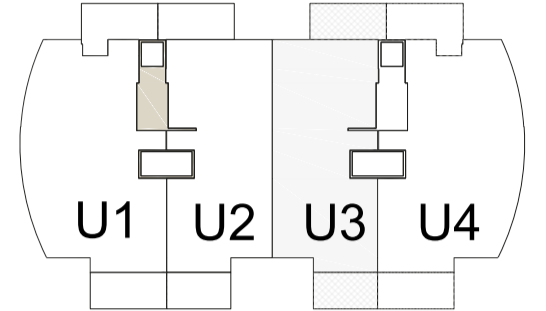
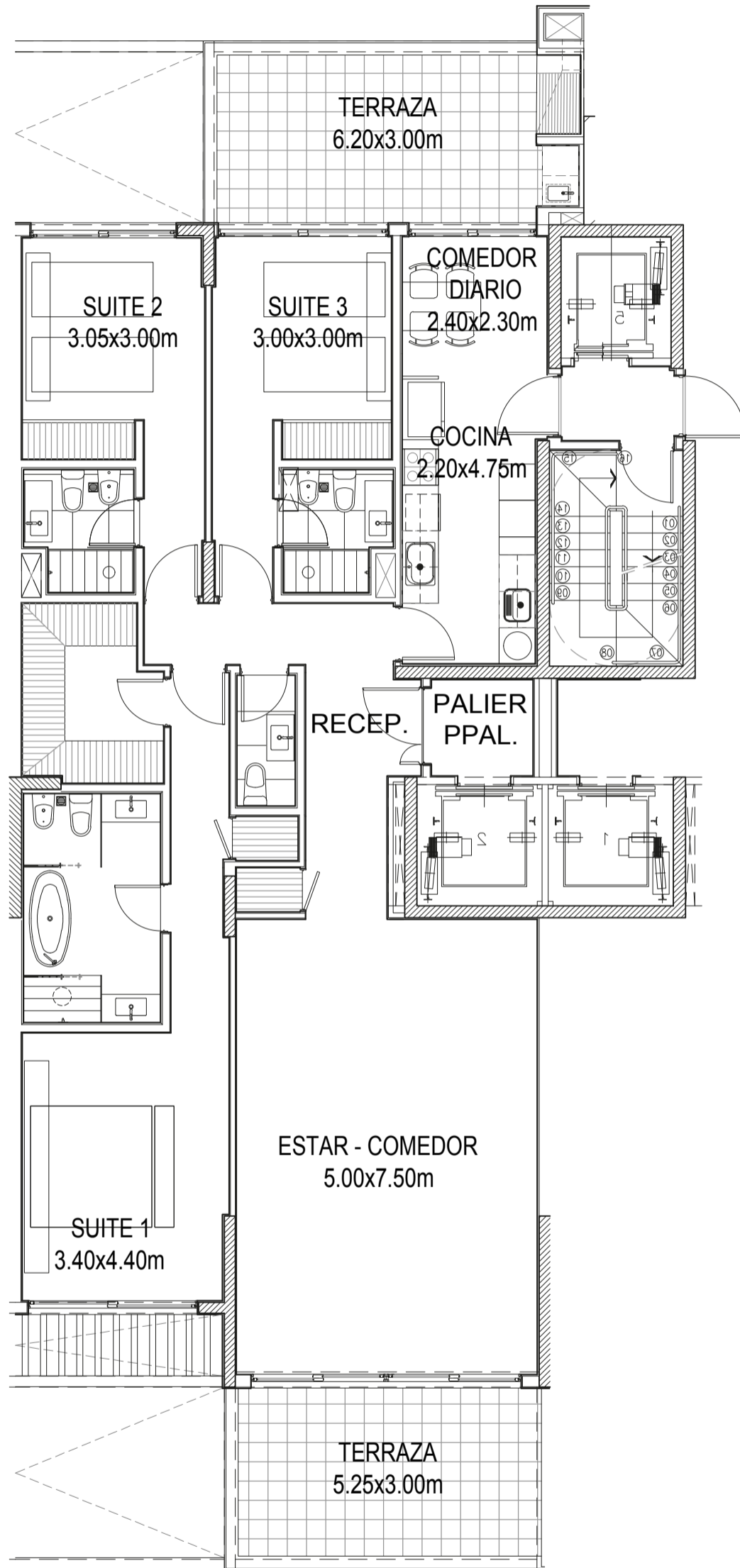

Planta tipo Unidad 3

Sup. Cubierta:	157.45 m ²
Sup. Semicubierta:	34.78 m ²
Sup. Común:	8.58 m ²
Sup. Amenities:	11.02 m ²
Sup. Cochera + Baulera:	15.00 m ²
Sup. Total:	226.83 m ²

PROYECTO

MRA+A
ARQUITECTOS

DESARROLLO

ALPES
PROPERTY MANAGEMENT

ASESORA

URBANIA
DESARROLLOS

DIRECCIÓN DE OBRA

LE
ARQUITECTURA

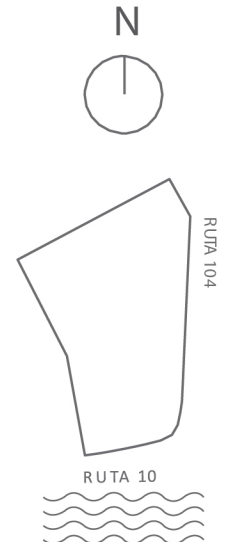
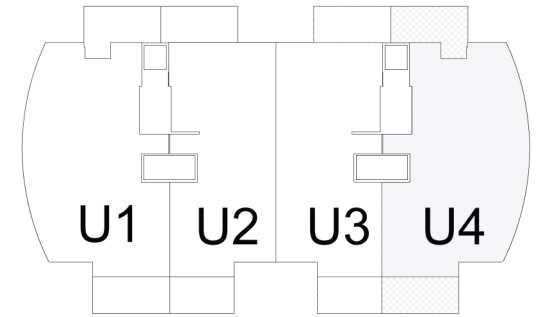
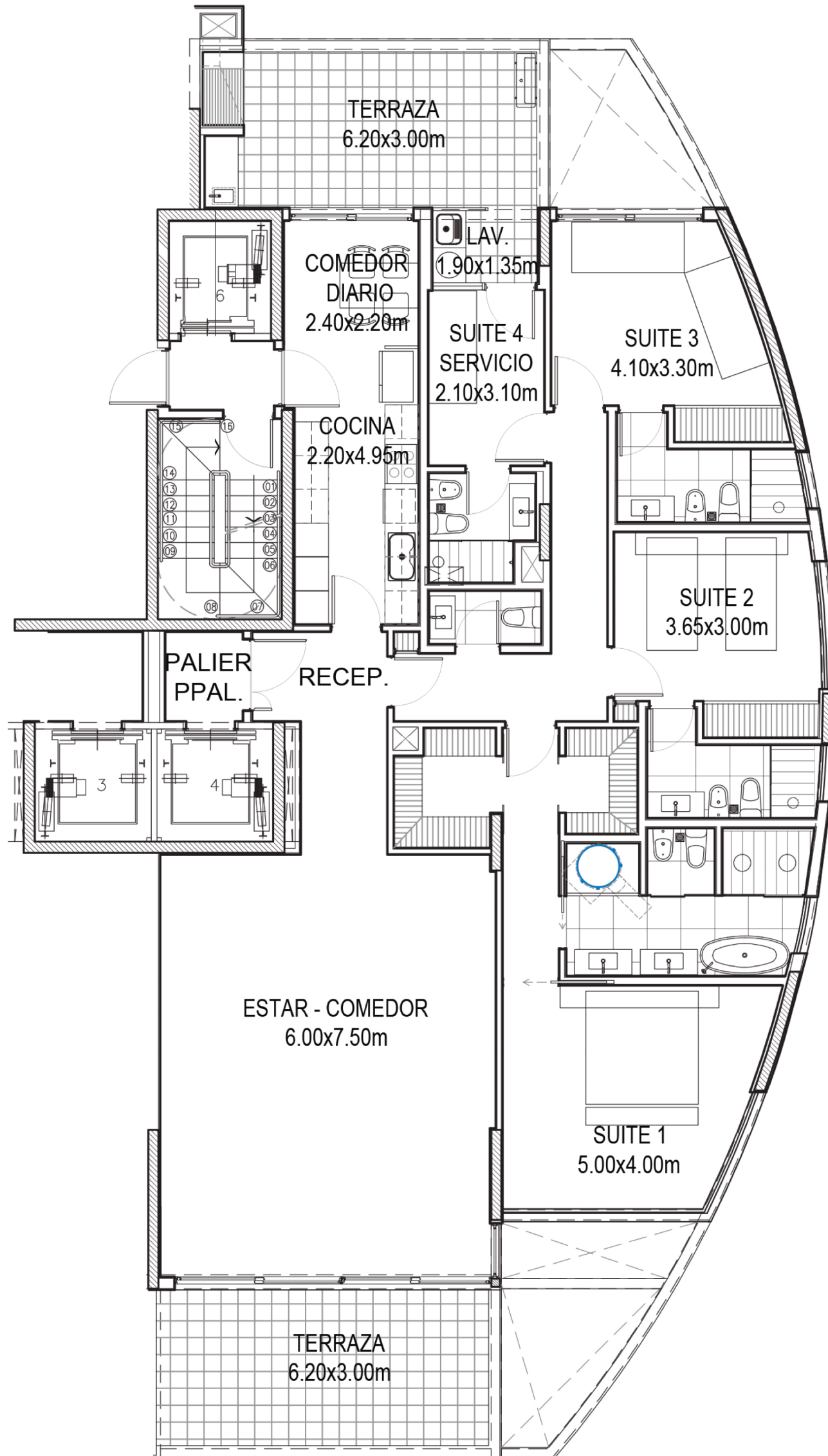

Planta tipo
Unidad 4

Sup. Cubierta:	187.05 m ²
Sup. Semicubierta:	40.42 m ²
Sup. Común:	8.58 m ²
Sup. Amenities:	13.10 m ²
Sup. Cochera + Baulera:	15.00 m ²
Sup. Total:	264.15 m ²

PROYECTO

MRA+A
ARQUITECTOS

DESARROLLO

ALPES
PROPERTY MANAGEMENT

ASESORA

URBANIA
DESARROLLOS

DIRECCIÓN DE OBRA

LE
ARQUITECTURA

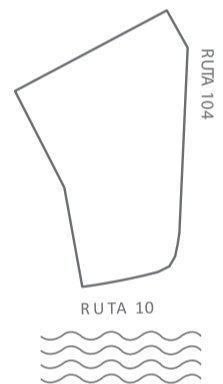
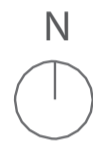
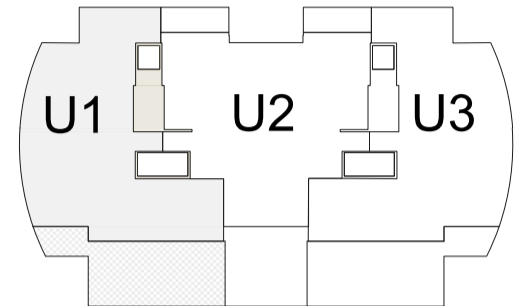
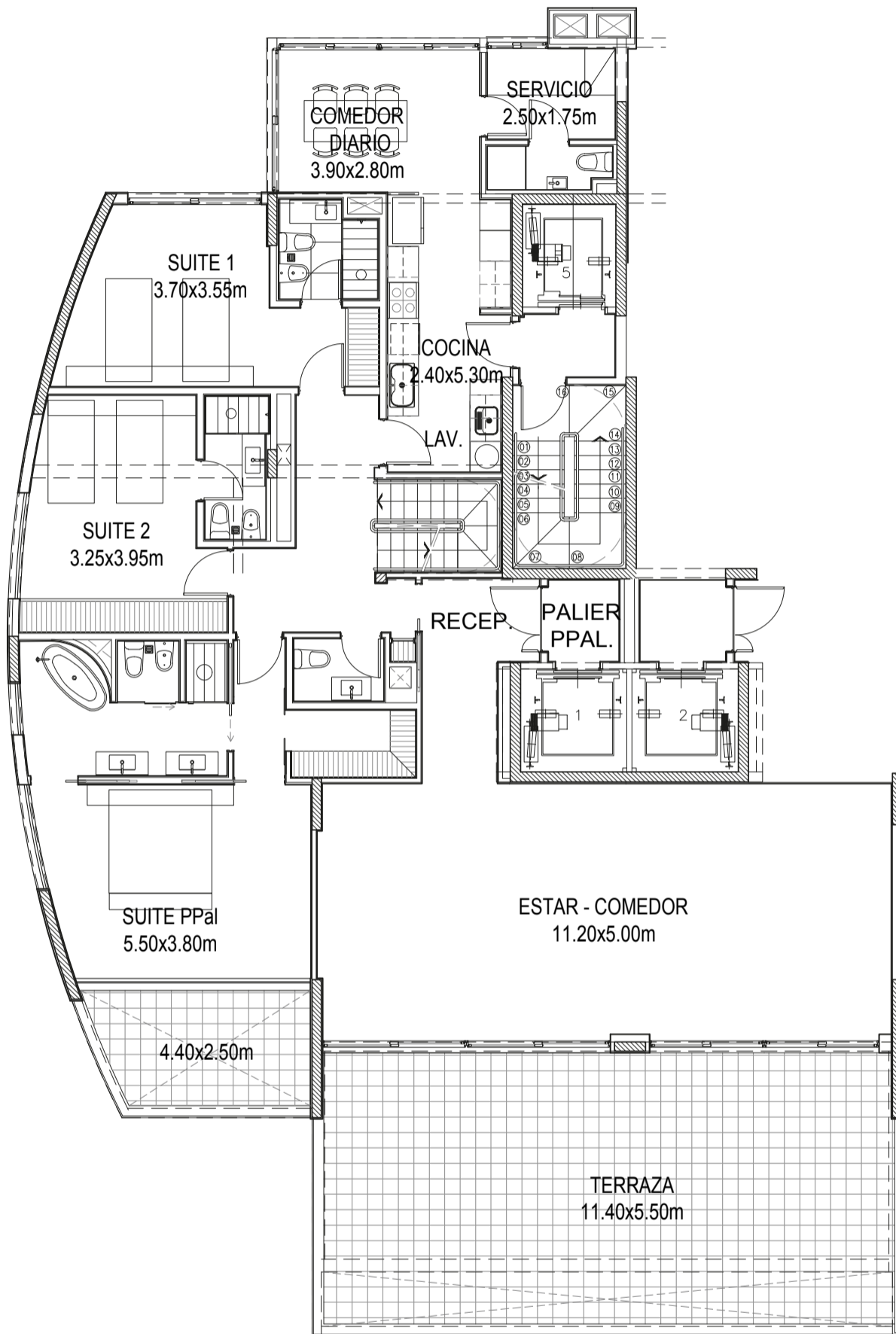

Penthouse Unidad 1 Planta Inferior

Sup. Cubierta:	211.80 m ²
Sup. Terraza Semic.:	48.84 m ²
Sup. Terraza Desc.:	24.66 m ²
Sup. Común:	8.58 m ²
Sup. Amenities:	14.82 m ²
Sup. Cochera + Baulera:	15.00 m ²
Sup. Total Planta Inf.:	323.70 m ²
Sup. Total Planta Sup.:	94.62 m ²
Sup. Total Unidad.:	418.32 m ²

PROYECTO

MRA+A
ARQUITECTOS

DESARROLLO

ALPES
PROPERTY MANAGEMENT

ASESORA

URBANIA
DESARROLLOS

DIRECCIÓN DE OBRA

LE
ARQUITECTURA

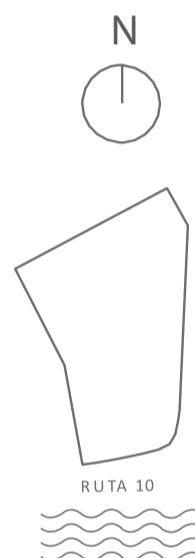
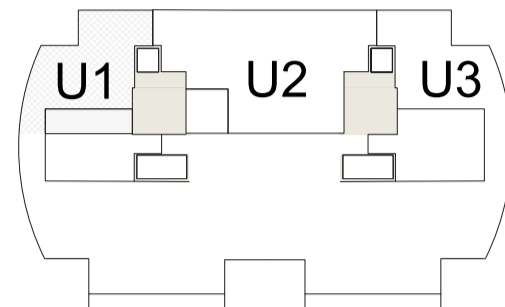
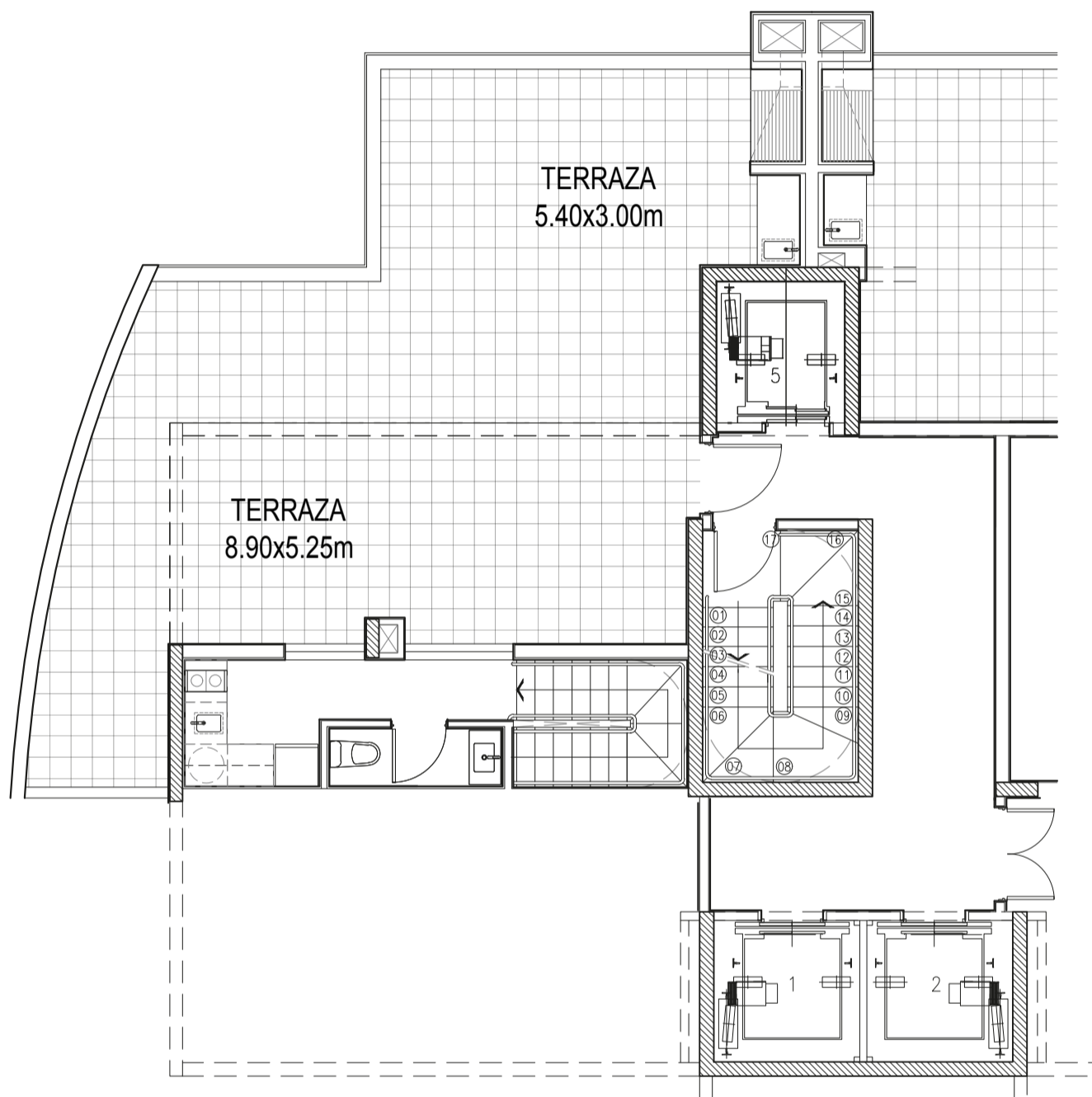

Penthouse Unidad 1 Planta Superior

Sup. Cubierta:	15.76 m ²
Sup. Terraza:	70.54 m ²
Sup. Común:	8.58 m ²
Sup. Total Planta Sup.:	94.62 m ²

PROYECTO

MRA+A
ARQUITECTOS

DESARROLLO

ALPES
PROPERTY MANAGEMENT

ASESORA

URBANIA
DESARROLLOS

DIRECCIÓN DE OBRA

LA
ARQUITECTURA

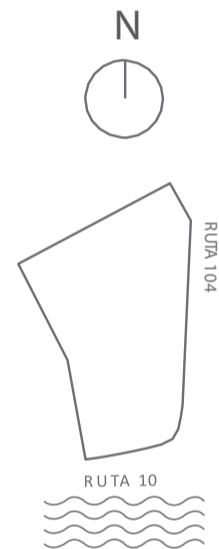
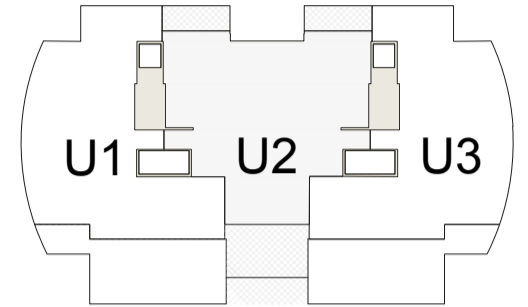
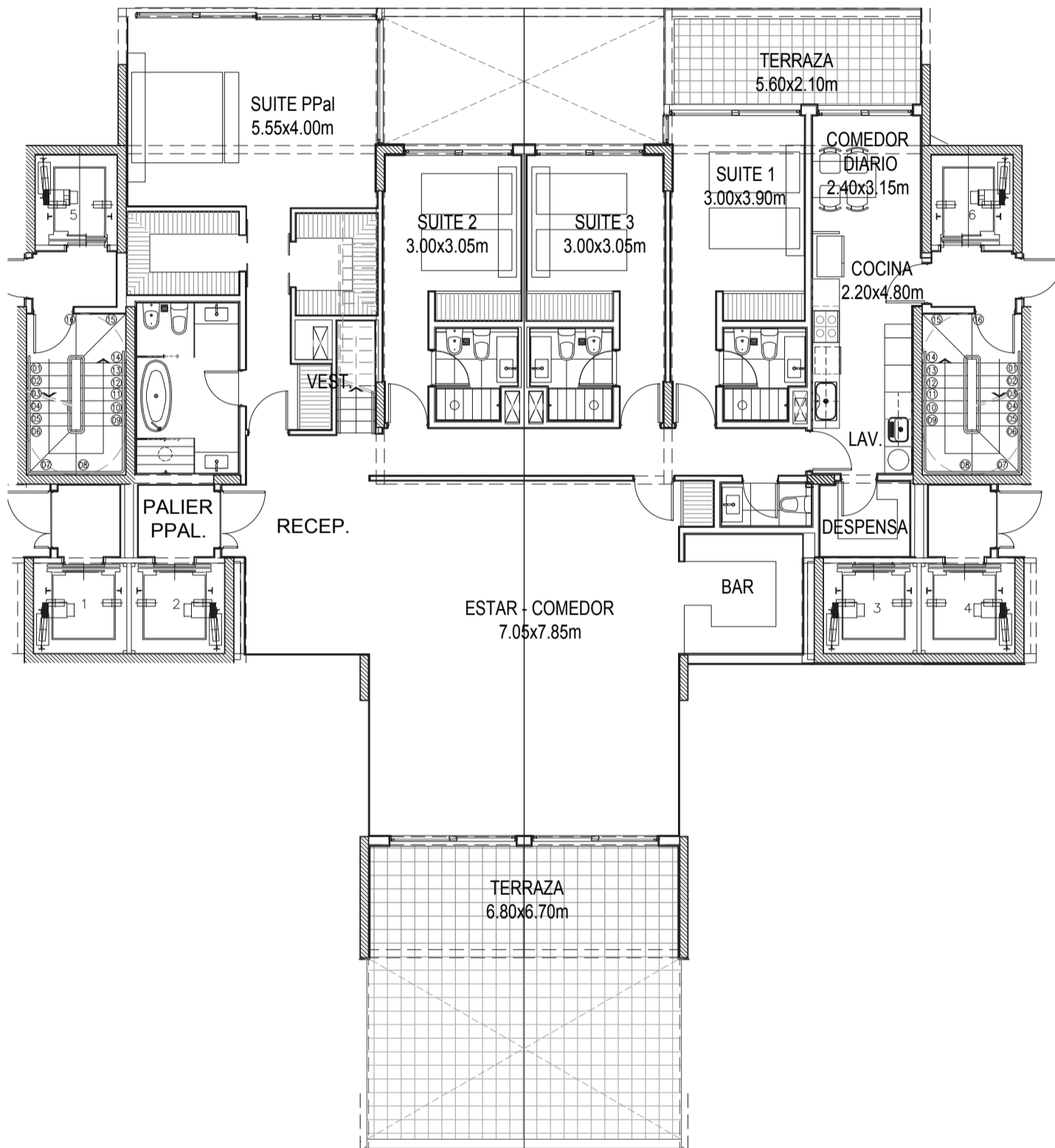

Penthouse Unidad 2 Planta Inferior

Sup. Cubierta:	239.04 m ²
Sup. Terraza Semic.:	29.60 m ²
Sup. Terraza Desc.:	29.93 m ²
Sup. Común:	8.58 m ²
Sup. Amenities:	15.91 m ²
Sup. Cochera + Baulera:	15.00 m ²
Sup. Total Planta Inf.:	338.05 m ²
Sup. Total Planta Sup.:	172.51 m ²
Sup. Total Unidad. :	510.56 m ²

PROYECTO

MRA+A
ARQUITECTOS

DESARROLLO

ALPES
PROPERTY MANAGEMENT

ASESORA

URBANIA
DESARROLLOS

DIRECCIÓN DE OBRA

LA
ARQUITECTURA

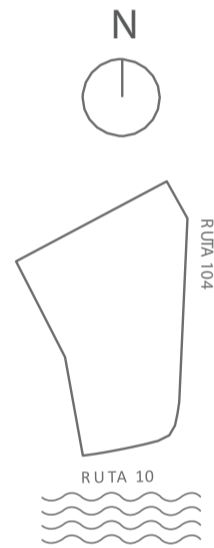
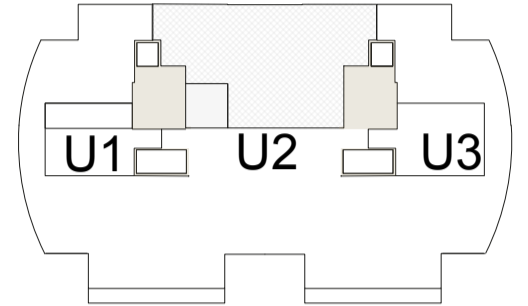
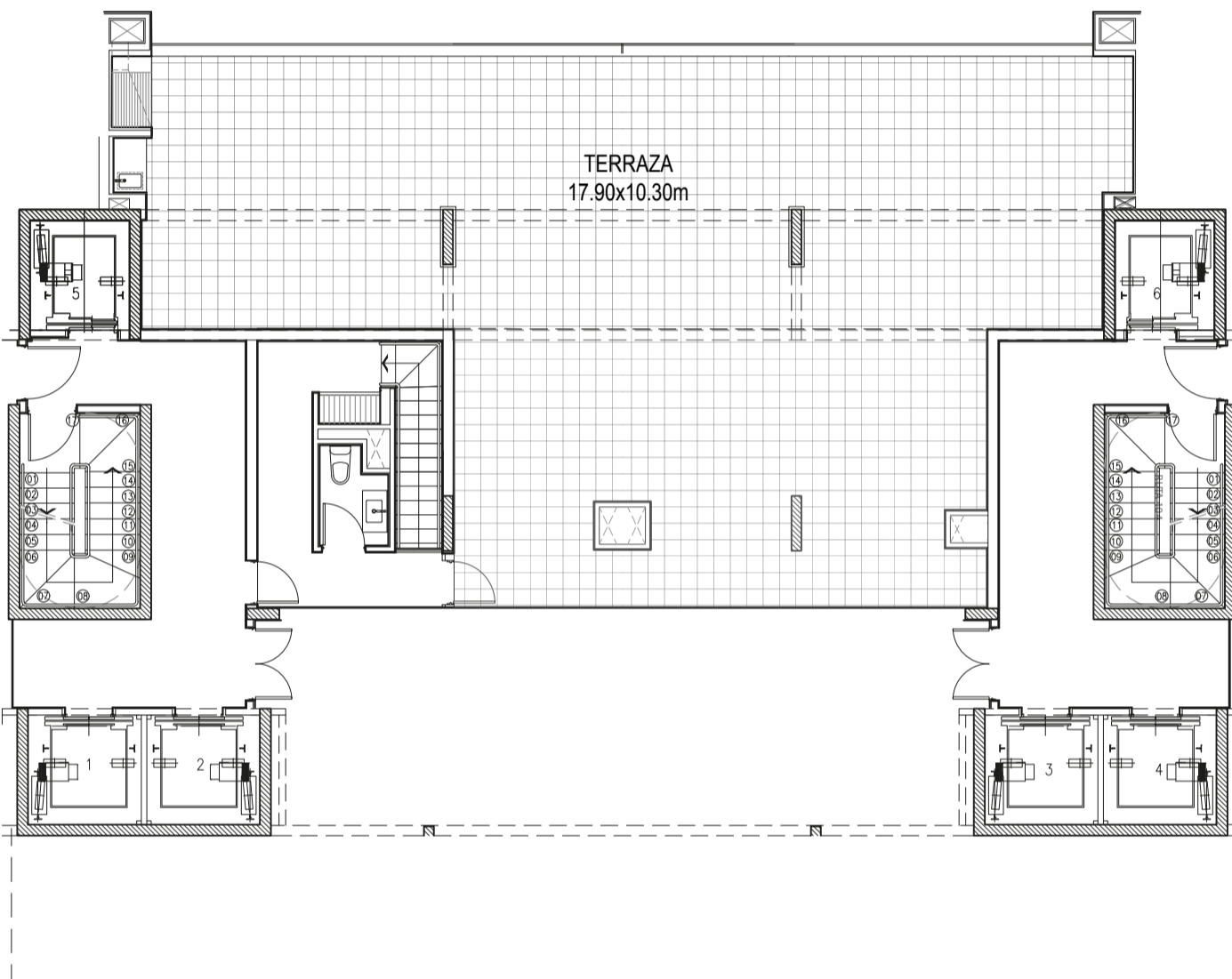

Penthouse Unidad 2 Planta Superior

Sup. Cubierta:	18.82 m ²
Sup. Terraza Semic.:	49.42 m ²
Sup. Terraza Desc.:	95.70 m ²
Sup. Común:	8.58 m ²
Sup. Total Planta Sup.:	172.51 m ²

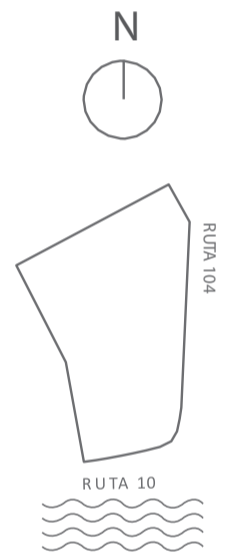
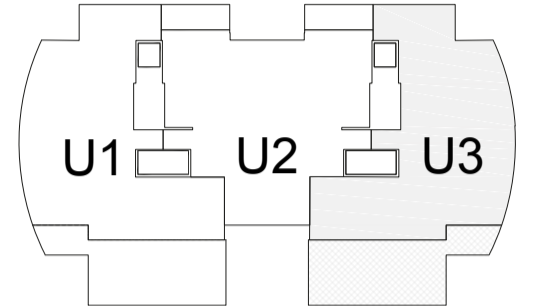
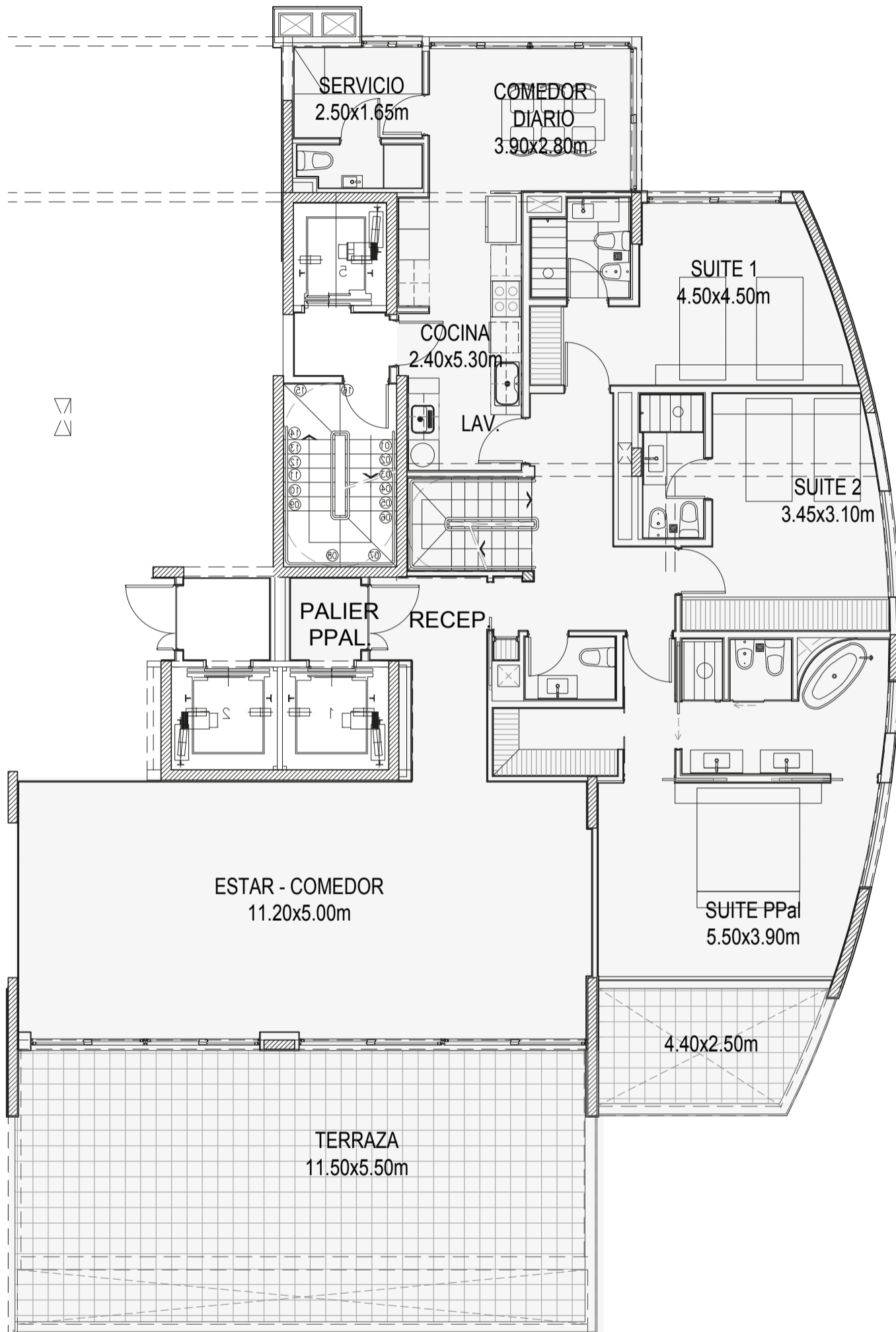

Penthouse Unidad 3 Planta Inferior

Sup. Cubierta:	211.80 m ²
Sup. Terraza Semic.:	48.84 m ²
Sup. Terraza Desc.:	24.66 m ²
Sup. Común:	8.58 m ²
Sup. Amenities:	14.82 m ²
Sup. Cochera + Baulera:	15.00 m ²
Sup. Total Planta Inf.:	323.70 m ²
Sup. Total Planta Sup.:	94.62 m ²
Sup. Total Unidad.:	418.32 m ²

PROYECTO

MRA+A
ARQUITECTOS

DESARROLLO

ALPES
PROPERTY MANAGEMENT

ASESORA

URBANIA
DESARROLLOS

DIRECCIÓN DE OBRA

LA
ARQUITECTURA

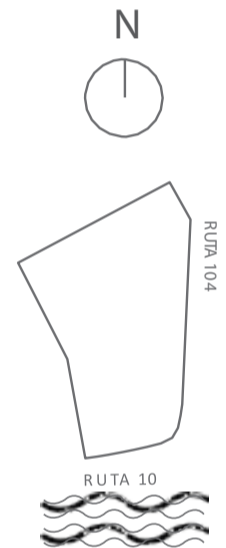
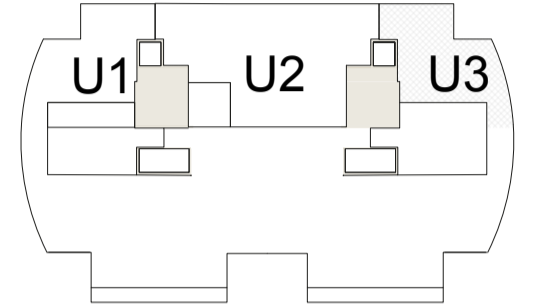
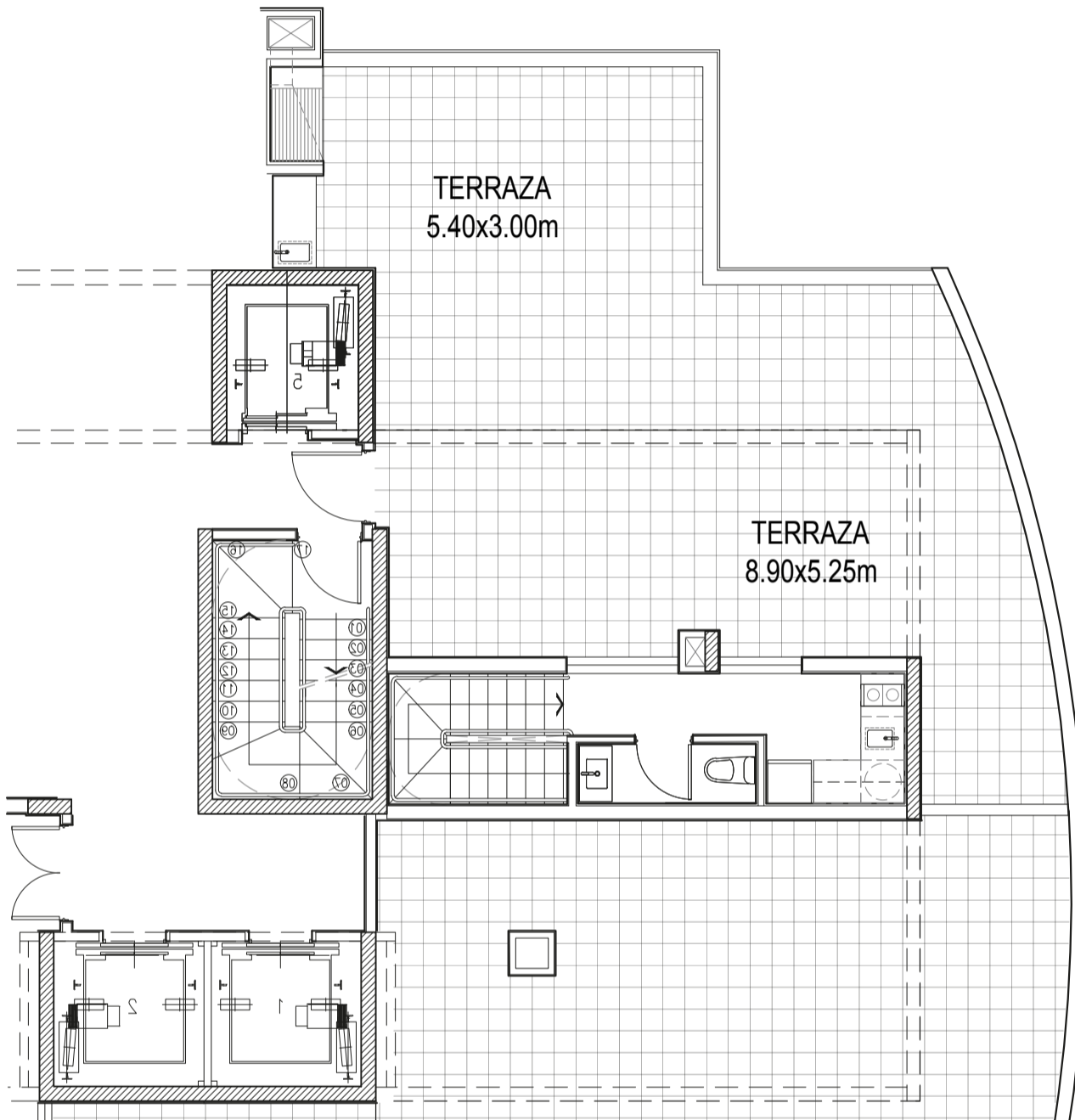

Penthouse Unidad 3 Planta Superior

Sup. Cubierta:	15.50 m ²
Sup. Terraza:	70.54 m ²
Sup. Común:	8.58 m ²
Sup. Total Planta Sup.:	94.62 m ²

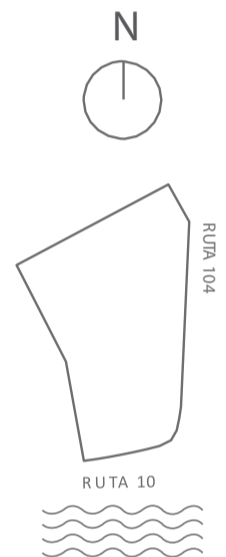
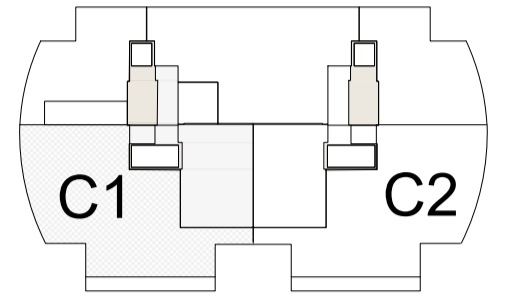
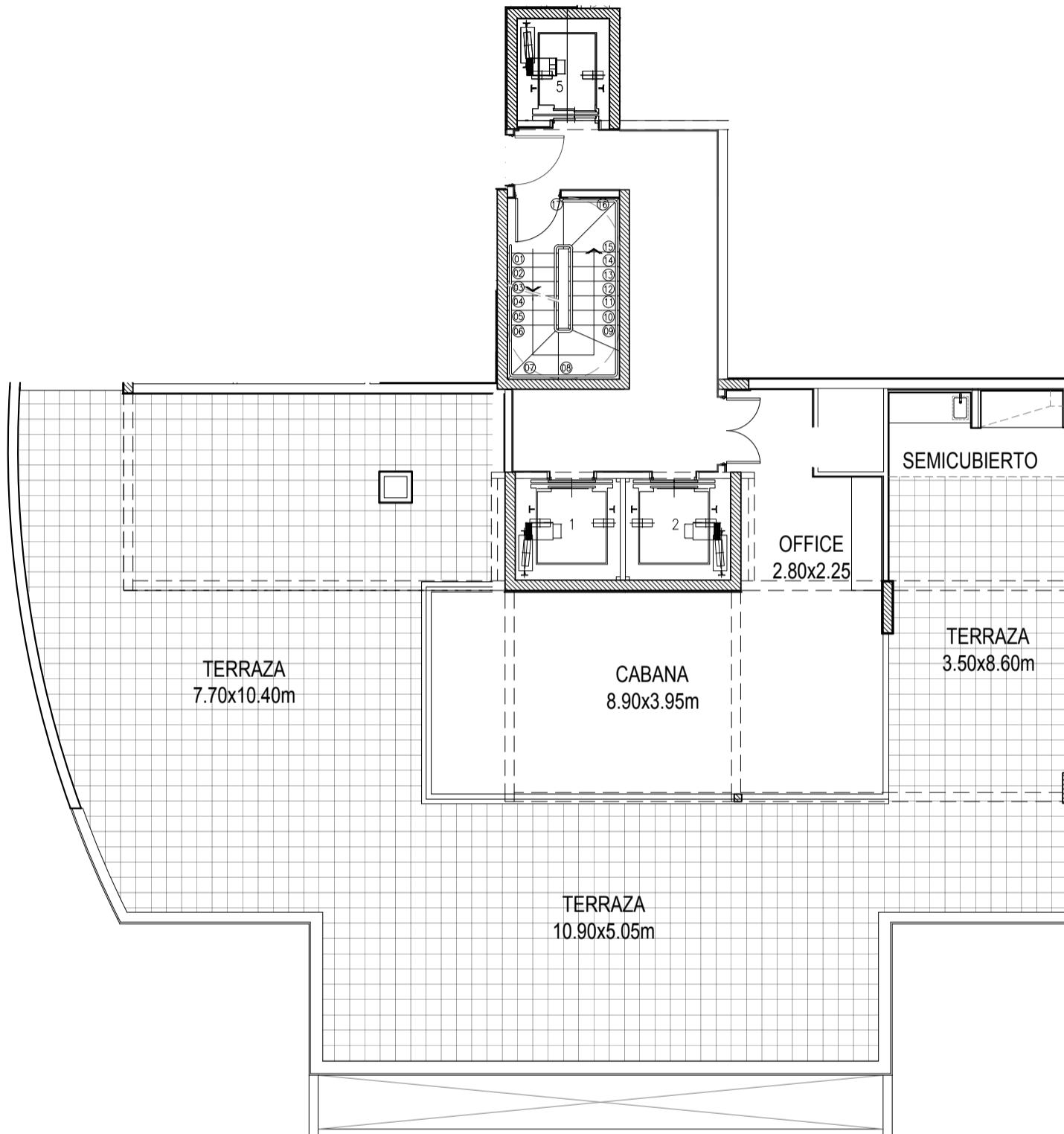

Cabana 1

Sup. Cubierta:	50.59 m ²
Sup. Semicubierta.:	6.44 m ²
Sup. Terraza:	170.07 m ²
Sup. Común:	18.78 m ²
Sup. Total Planta Sup.:	245.64 m ²

PROYECTO

MRA+A
ARQUITECTOS

DESARROLLO

ALPES
PROPERTY MANAGEMENT

ASESORA

URBANIA
DESARROLLOS

DIRECCIÓN DE OBRA

LA
ARQUITECTURA

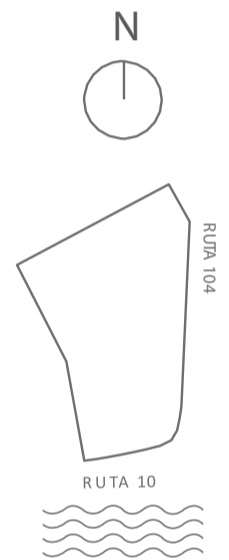
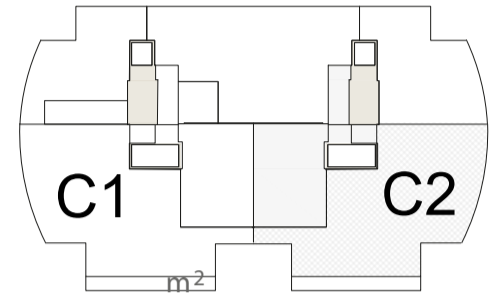
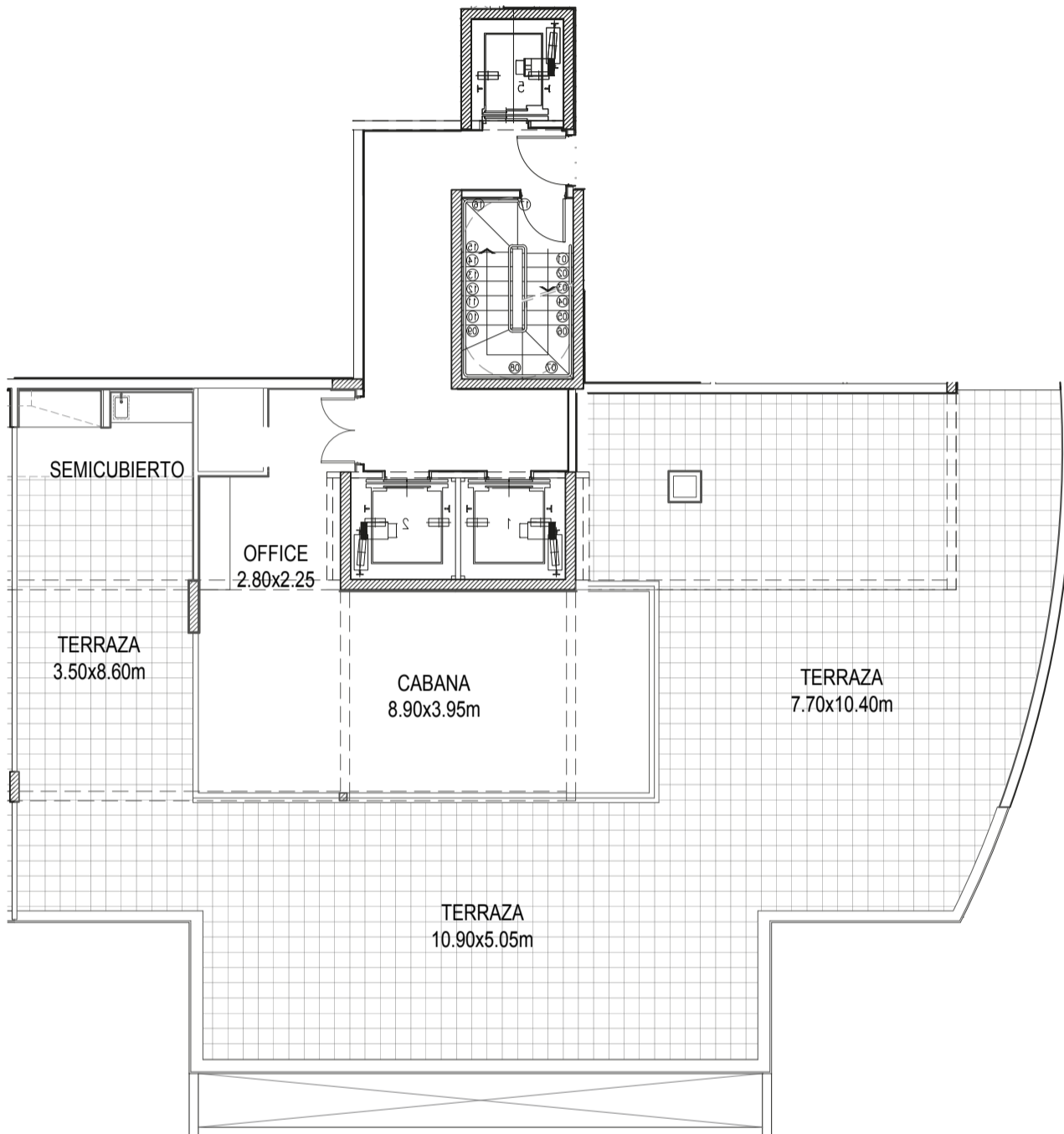

Cabana 2

Sup. Cubierta:	50.59 m ²
Sup. Semicubierta:	6.44 m ²
Sup. Terraza:	170.07 m ²
Sup. Común:	18.78 m ²
Sup. Total Planta Sup.:	245.64 m ²